

Programmed with HCT's Intella Software Suite™

14 I/O (8 inputs & 6 outputs), 1 CAN interface
Supply voltage 9-30Vdc

The DVC707 is a robust programmable controller for solenoid-operated proportional valves. It is uniquely designed with configurable I/O and one CAN communication port. This controller has fewer I/O than the DVC710, making it more affordable for smaller stand-alone applications. However, it can also be utilized as a system master module or as an expansion module for the DVC700 series controllers.

- Advanced stand-alone programmable controller
- Total system master controller when combined with DVC700 series expansion modules
- Selectable PID closed-loop processes for pressure/speed control
- Configurable inputs and outputs
- Configurable input and output function curves
- CAN communication
- Current regulated outputs
- Open/short detection for diagnostics
- Auto scale outputs for EDC valves (1 to 125 mA)
- Rugged and fully encapsulated
- SAE J1455 environment and load dump compliant
- IP67, 69K
- CE Certified



Operational Specifications

Supply Voltage	9-30 V _{DC} (recommended operating voltage +12 to +28 V _{DC} , absolute maximum +/-32 V _{DC})
Supply Current	15 Amps (recommended supply current per power pin 5 Amps, absolute maximum 8 Amps)
Operating Temperature	-40 to +85°C
Storage Temperature	-40 to +100°C
Weight	1.29 lbs (0.58 kg)
Dimensions	L: 5.50 in (140 mm) x W: 4.70 in (119 mm) x H: 1.65in (42 mm)
Enclosure	Solid potted, industry standard Deutsch enclosure with automotive connectors
NEMA / IP Rating	NEMA 6P / IP67, 69K

Communication

CAN	2.0B (maximum voltage +/-14V _{DC})
	Baud rates 125 kb/s, 250kb/s, 500kb/s, software configurable
	Protocol SAE J1939, HCT DeviceNet
	Default baud rate 250kb/s
Serial Interface	RS232 (maximum voltage Rxd,RTS = +/-15V _{DC} Txd = +/-8 V _{DC})

Inputs

Digital (Qty 3)	Discrete high/low, pulse (RPM and count), software configurable
Input Range	0 to +Supply, (Impedance Z = 32.4KΩ) Pulse: RPM/Pulse inputs will accept up to 24kHz on all RPM/Pulse inputs combined
Debounce Time	0 to 10 seconds, 10ms intervals, software configurable
Analog (Qty 2)	0 - 5 V _{DC} , digital, (Impedance Z > 100KΩ), software configurable (Note: 2)
Universal (Qty 3)	0 - 5 V _{DC} , 4 - 20 mA, digital, pulse (RPM, count, and quadrature), software configurable (Note: 2)
Input Range	Current mode: 0 to +22 mA maximum allowable current, (Impedance Z = 120KΩ) Pulse: RPM/Pulse inputs will accept up to 24kHz on all RPM/Pulse inputs combined

NOTE: 1) Maximum voltage on any input pin +/-32 V_{DC}
2) Analog and Universal inputs have configurable calibration, center and inverse modes

Outputs

Digital (Qty 6)	3,000 mA sourcing, software configurable
Current Leakage	Off = 370μA, Supply = +28 V _{DC} Off = 180μA, Supply = +13.6 V _{DC}
Diagnostics	Open/short circuit detection
Fly back protection	Integrated
PWM (Qty 2)	DVC707: 0 - 3,000 mA sinking proportional 10-bit resolution, software configurable DVC707LC: 0 - 1,500 mA sinking proportional 10-bit resolution, software configurable
Dither Frequency	1 - 500 Hz, software configurable
Diagnostics	Open/short circuit detection
Fly back protection	Integrated
Reference Output	0 - 5 V _{DC} (500 mA Max)

Standards

Environmental	SAE J1455	Immunity	89/336/EEC, EN 61000-6-2
Temperature	Section 4.1.3.2	ESD	EN 61000-4-2
Salt Spray	Section 4.3.3.1	EMC	EN 61000-4-3
Steam Cleaning & Pressure Washing	Section 4.5.3.2	EMC	EN 61000-4-4
Vibration	Section 4.10.4.2	RF	EN 61000-4-6
Shock	Section 4.11.3.4	Emissions	89/336/EEC, EN 61000-6-4
Load Dump	Section 4.13.2.2.1.a		EN 55011

Certifications

CE Mark

Pin Out

30 Pin Cinch					
Pin	Function	Pin	Function	Pin	Function
L1	TXD	M1	CAN H	N1	CAN L
L2	RXD	M2	PWR COM	N2	PWR COM
L3	RTS	M3	PWR COM	N3	PWR COM
P1	UNI 1 INPUT	R1	UNI 2 INPUT	S1	UNI 3 INPUT
P2	ANA 1 INPUT	R2	ANA 2 INPUT	S2	DIG 1 INPUT
P3	PWR COM	R3	5V REF OUTPUT	S3	DIG 2 INPUT
T1	HS 1 OUTPUT	W1	PWM 1 OUTPUT	X1	HS 2 OUTPUT
T2	HS 3 OUTPUT	W2	PWM 2 OUTPUT	X2	HS 4 OUTPUT
T3	DIG 3 INPUT	W3	HS 5 OUTPUT	X3	HS 6 OUTPUT
Y1	+ POWER IN				
Y2	+ POWER IN				
Y3	+ POWER IN				

Recommended Operating Parameters / Pin Functions

Pin	Name	Function/Features	Range
Y1, Y2, Y3	Power In	Positive Power Supply Input	+12V _{DC} to +28V _{DC} (Note: 1)
M2, M3, N2, N3, P3	Power Common	Return for Power Supply and Sensors	0 Volts (GND) (Note: 1)
C2, D2, E2	Universal Inputs (Notes: 3, 4, 6)	Analog Digital Pulse (RPM) Counter Quadrature (Uni_2 & 3)	0-5Volts (Notes: 3, 4, 6) 4-20mA
R3	5V REF	Reference Output	5 V _{DC} , 500mA
S2, S3, T3	Digital Inputs	On / Off. RPM	0 to +Supply (Note: 5, 6)
P2, R2,	Analog Inputs	Analog Active Low Digital	0-5 V _{DC} (Note: 3) 0 to +Supply
T1, T2, W3, X1, X2, X3	High Side Outputs	Sourcing Discreet Output	On = +Supply 3,000mA (0-1,500mA DVC707LC) Off = +Supply 370µA, Supply = 28V _{DC} Off = +Supply 180µA, Supply = 13.6V _{DC}
W1, W2	PWM Outputs	Sinking PWM Output	10 bit resolution 0 to +Supply 0 to 3,000 mA (0-1,500mA DVC707LC)

Notes:

1. Maximum continuous current allowed on any single connector Pin = 8 Amps
2. All limits are guaranteed by testing or statistical analysis
3. Input impedance, 100KΩ with respect to Ground (0V_{DC})
4. Input impedance, 120Ω with respect to Ground (0V_{DC})
5. Input impedance, 32.4KΩ with respect to Ground (0V_{DC})
6. RPM/Pulse inputs will accept up to 24kHz on all RPM/Pulse inputs combined

LED Diagnostic Indicators

Module Status	
LED STATE	MEANING
Off	There is no power applied to the module.
On GREEN	The module is operating in a normal condition.
Flashing GREEN	Device is in standby state. May need servicing.
On RED	Module has an unrecoverable fault.
On YELLOW	System Disabled active
Flashing RED	Low Supply Voltage.

CAN Status	
On GREEN	Communication established with another Master Controller
Flashing GREEN	Waiting to establish communication with the Master Controller
On RED	The device has detected an error that has rendered it incapable of communicating on the network.
Flashing RED	The DVC Devicenet communication is in a timed-out state

% Current O/P	
LED STATE	MEANING
Off (Outputs Disabled) GRN (0-33%) YEL (34-66%) RED (66-100%)	
Flashing GREEN	PWM or High Side output Open circuit detected
Flashing RED	PWM or High Side output Short circuit detected

Error Status	
LED STATE	MEANING
Off	No errors
On RED	PWM1 Open or Short Detected
On GREEN	PWM2 Open or Short Detected
Flashing YELLOW	High Side Open or Short Detected
Multi Digit Blink Code	Application defined blink codes.

Physical Description

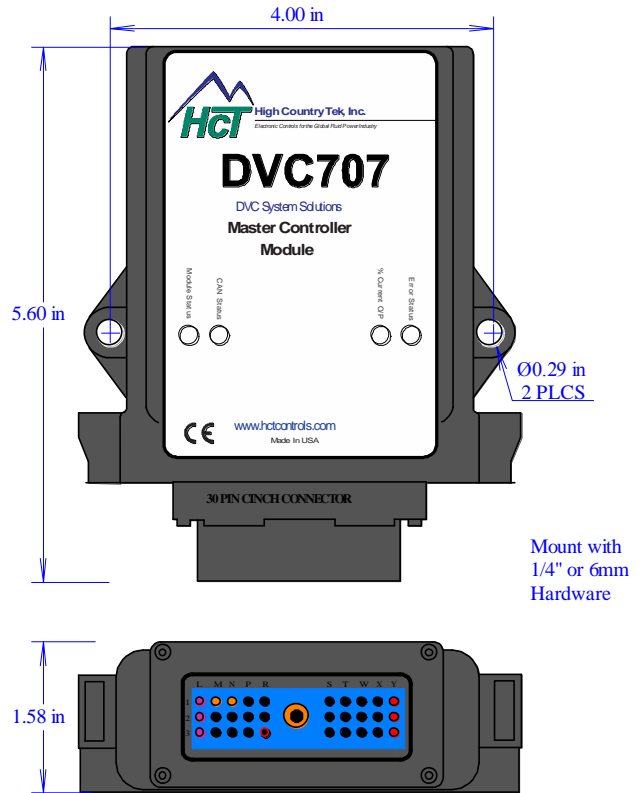

Notes:

- 1) All dimensions are in Inches (Millimeters).
- 2) Use 1/4 x 20 SAE Grade 2 bolts (M6 x 1 ISO Grade 8)
 - * Torque to 4 ft-lbs (5.4 N-m) Dry
 - * Torque to 3 ft-lbs (4.1 N-m) Oiled
- 2) Mount to a flat hard surface protected from excess heat and moving parts.
- 3) Factory recommended 18-22 AWG (1.02mm to 0.64mm) TXL, XSL, and GXL automotive grade wire
- 4) Each Power pin used must be individually fused with an ATO 5, AGC 5 or smaller fuse

Mount with 1/4" or 6mm Hardware

Connections

Module Connector - 30 Pin	Cinch 581-01-30-002
Mating Connector - 30 Pin	Delphi Packard 15492542-B
Mating Connector Pins	Delphi Packard 12103881

Order Guide

Part Number	Description
DVC707	2x dual channel master controller, 1x CAN ports (0 to 3 Amp output)
DVC707LC	2x dual channel master controller, 1x CAN ports (0 to 1.5 Amp output)
999-10310	DVC707 QPS Kit (includes 1x DVC707, 1x 999-10141, 1x 999-10075, 1x 108-00119)
999-10311	DVC707LC QPS Kit (includes 1x DVC707LC, 1x 999-10141, 1x 999-10075, 1x 108-00119)
999-10075	Communications Cable, multi-controller, 4-way to PC (RS232), 2m length, auto-grade
108-00119	Adapter, USB to RS232, use with 999-10075 assembly, only required if PC has no RS3232 'D' ports
999-10076	Serial port adapter for program updates, 4 wires
999-10321	DVC707, 30 pin connector kit with 1x CANbus (Deutsch) connector shell + pins, and serial port adapter 999-10076, assembly required
999-10317	DVC707, 30 pin prototype harness with 1x CANbus (Deutsch), 3m length, auto grade with serial port adapter 999-10076

DVC707 Output Features

Output Groups (Qty2)	Designed with 3 output groups consisting of 2x digital sourcing outputs and 1x PWM sinking output allowing the
Dual Coil High-Side	To be used with proportional dual coil applications
Single Coil High-Side	Independently control a single proportional output and a single discrete output
Single Coil Low-Side	Independently control a single proportional output and two discrete outputs
High-Side Only	Independently control two discrete outputs

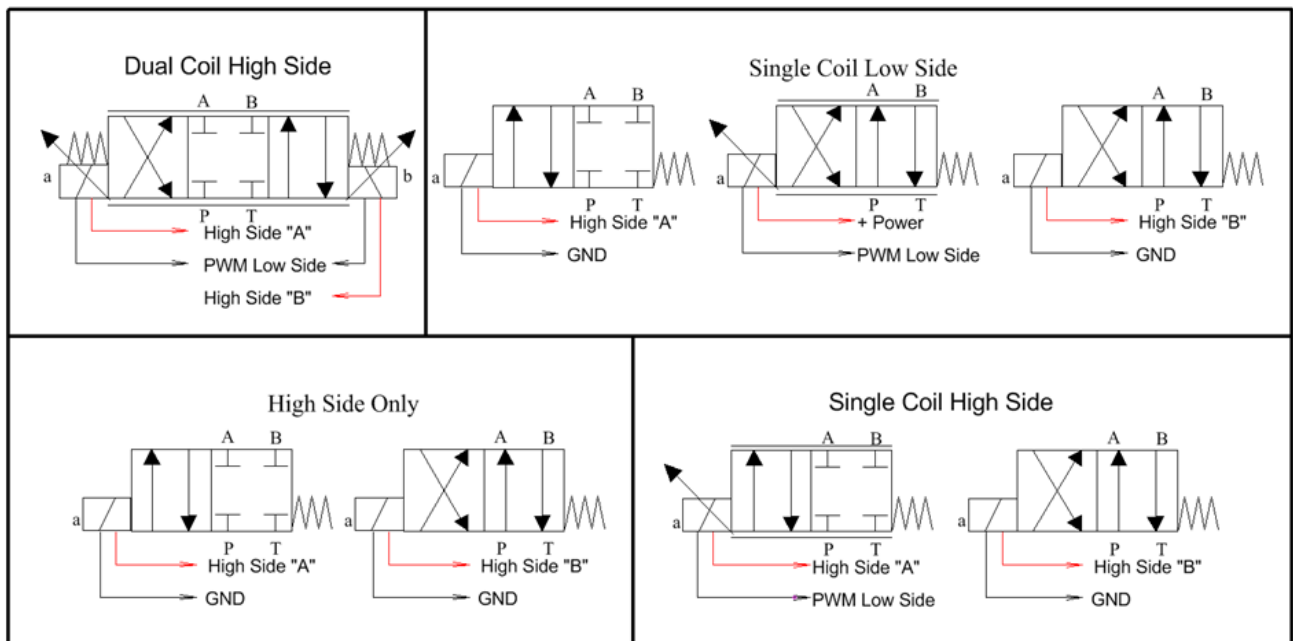

Figure 1: DVC707 output configurations.

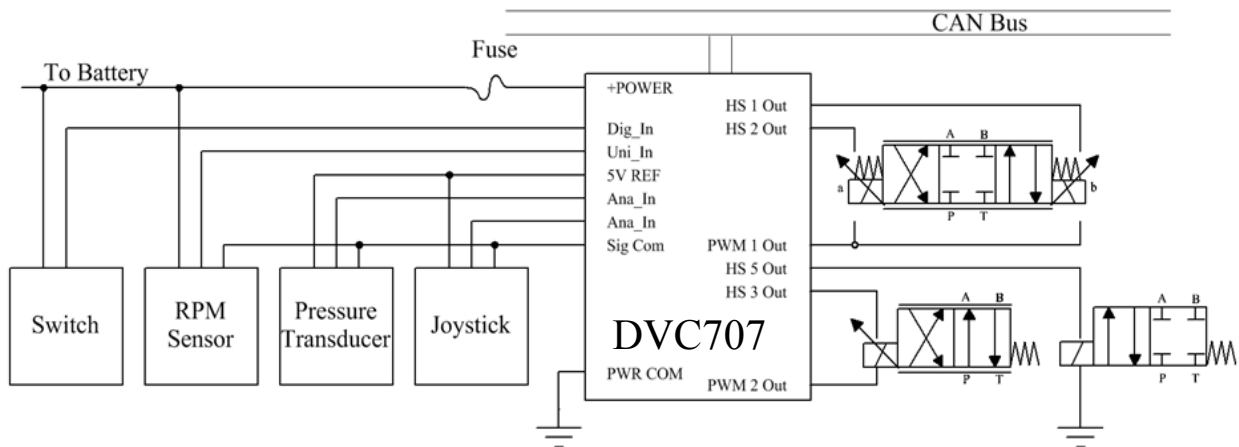

Figure 2: DVC707 example wiring diagram using two different output group configurations.

HCT Headquarters
208 Gold Flat Court
Nevada City, CA 95949 U.S.A.
Phone: 530.265.3236

Sun Hydraulics Corporation Headquarters
1500 West University Parkway
Sarasota, FL 34243 U.S.A.
Phone: 941.362.1200

ONE RELIABLE SOURCE ENDLESS SOLUTIONS



Sun Hydraulics Limited
Wheler Road
Coventry CV3 4LA
England
Ph: +44-2476-217-400

Sun Hydraulik GmbH.
Brüsseler Allee 2
D-41812 Erkelenz
Germany
Ph: +49-2431-8091-0

Sun Hydraulics Corporation
Parc Innolin
6 Rue du Golf
33700 Merignac
France
Ph: +33-673063371

Sun Hydraulics Korea Corp.
92 Hogupo-ro
Namdong-gu
Incheon 405-818
Korea
Ph: +82-32-813-1350

Sun Hydraulics China Co. Ltd
Hong Kong New World Tower
47th Floor
300, Huaihai Zhong Road
Shanghai 200021
P.R. China
Ph: +86-21-5116-2862

Sun Hydraulics (India)
No.48 'Regent Prime'
Unit No. 306, Level 3
Whitefield Main Road, Whitefield
Bangalore – 560 066
India
Ph: +0091-80-28456325