

Return line filters, tank-top type FRS

Threaded ports - max flow 550 l/min, max pressure 8 bar

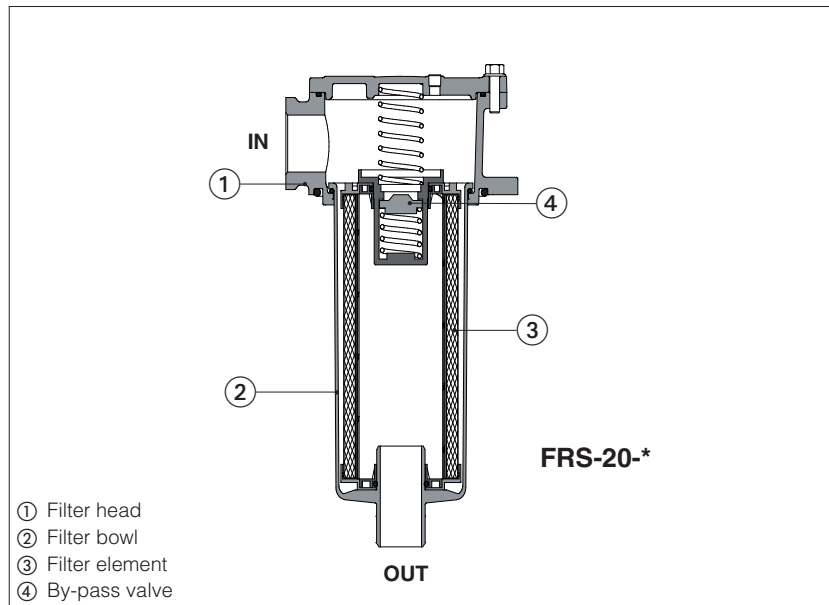

- ① Filter head
- ② Filter bowl
- ③ Filter element
- ④ By-pass valve

FRS return line filters are designed to protect pumps and the whole hydraulic circuit from contamination present in the working fluid.

They are specific for installation on the top of the hydraulic tank.

FRS filters are available with following features:

- four body sizes with BSPP, NPT or SAE threaded ports, from 1/2" to 2"
- four filter lengths with max flow up to 550 l/min
- by-pass valve with cracking pressure 3 bar
- microfibre filter element with filtration rating 12 or 27 μm(c) (βx(c) >1000, ISO 16889)
- without or with electrical or visual clogging indicators

1 MODEL CODE OF COMPLETE FILTERS

FRS	-	10	-	A	-	F10	-	00	-	R	-	W	-	**	/	*																														
Return line filter														Series number		Seals material: - = NBR PE = FKM (5)																														
<p>Filter size: 10 = ports size 1/2" ÷ 3/4" 20 = ports size 3/4" ÷ 1 1/4" 30 = ports size 1 1/4" ÷ 1 1/2" 40 = ports size 1 1/4" ÷ 2"</p>														<p>Clogging indicator see sect. 9 :</p> <p>W = without indicator (port plugged with steel plug) E = electrical indicator (4) V = visual indicator (4)</p>																																
<p>Filter</p> <table border="1" style="width: 100%; border-collapse: collapse;"> <thead> <tr> <th></th> <th colspan="4" style="text-align: center;">Max flow [l/min] (1)</th> </tr> <tr> <th style="text-align: left;">length:</th> <th style="text-align: center;">FRS-10</th> <th style="text-align: center;">FRS-20</th> <th style="text-align: center;">FRS-30</th> <th style="text-align: center;">FRS-40</th> </tr> </thead> <tbody> <tr> <td>A =</td> <td style="text-align: center;">45</td> <td style="text-align: center;">65</td> <td style="text-align: center;">275</td> <td style="text-align: center;">355</td> </tr> <tr> <td>B =</td> <td style="text-align: center;">55</td> <td style="text-align: center;">110</td> <td style="text-align: center;">-</td> <td style="text-align: center;">480 (2)</td> </tr> <tr> <td>C =</td> <td style="text-align: center;">-</td> <td style="text-align: center;">175</td> <td style="text-align: center;">-</td> <td style="text-align: center;">550 (2)</td> </tr> <tr> <td>D =</td> <td style="text-align: center;">-</td> <td style="text-align: center;">200</td> <td style="text-align: center;">-</td> <td style="text-align: center;">-</td> </tr> </tbody> </table>			Max flow [l/min] (1)				length:	FRS-10	FRS-20	FRS-30	FRS-40	A =	45	65	275	355	B =	55	110	-	480 (2)	C =	-	175	-	550 (2)	D =	-	200	-	-													<p>By-pass: R = by-pass valve with cracking pressure 3 bar</p>		
	Max flow [l/min] (1)																																													
length:	FRS-10	FRS-20	FRS-30	FRS-40																																										
A =	45	65	275	355																																										
B =	55	110	-	480 (2)																																										
C =	-	175	-	550 (2)																																										
D =	-	200	-	-																																										
<p>Microfibre filtration rating, βx(c) >1000 - ISO 16889: F10 = 12 μm (c) F25 = 27 μm (c)</p>																<p>Ports size: BSPP threaded: FRS-10 FRS-20 FRS-30 FRS-40 00 = G 1/2" 01 = G 3/4" 03 = G 1 1/4" 03 = G 1 1/4" 01 = G 3/4" 02 = G 1" 04 = G 1 1/2" 04 = G 1 1/2" 03 = G 1 1/4" 05 = G 2"</p> <p>NPT threaded (3): FRS-10 FRS-20 FRS-30 FRS-40 11 = 3/4" 13 = 1 1/4" 14 = 1 1/2" 15 = 2"</p> <p>SAE J1926-1 threaded (3): FRS-10 FRS-20 FRS-30 FRS-40 41 = SAE-12 (3/4") 43 = SAE-20 (1 1/4") 44 = SAE-24 (1 1/2") 45 = SAE-32 (2")</p>																														

- (1) Max flow rates are performed in following conditions:
 - clean filter element
 - filtration rating F25 (27 μm (c))
 - largest ports size
 - Δp = 0,5 bar
 - mineral oil with viscosity 30 mm²/s
 In case of different conditions the max flow rates have to be recalculated - see section 10
- (2) For FRS-40 with length B and C the max flow is limited by the max flow velocity allowed in the pipe connections
- (3) Filters with NPT or SAE threaded ports are available on request
- (4) The clogging indicator is supplied disassembled from the filter. The indicator port on filter head is plugged with steel plug
- (5) Filters with FKM seals are available on request

2 HYDRAULIC SYMBOLS (representation according to ISO 1219-1)

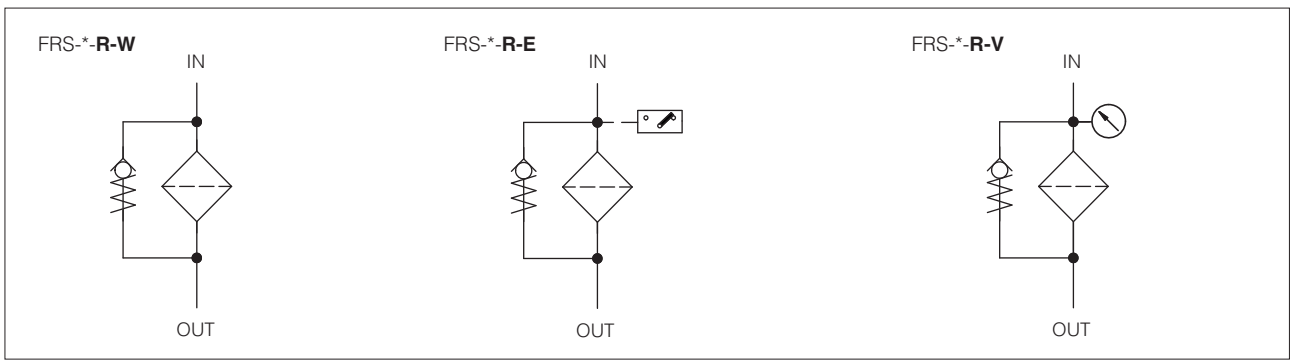

3 MODEL CODE OF FILTER ELEMENTS - only for spare (1)

<p>PRS</p> <p>Spare filter element for return line filter type FRS</p>	-	<p>10</p>	-	<p>A</p>	-	<p>F10</p>	<p>**</p> <p>Series number</p>	/	<p>*</p> <p>Seals material: - = NBR PE = FKM (2)</p>																				
						<p>Filter element size:</p> <p>10 = for FRS-10 20 = for FRS-20 30 = for FRS-30 40 = for FRS-40</p>																							
						<p>Microfibre filtration rating, $\beta_{x(c)} > 1000$ - ISO 16889:</p> <p>F10 = 12 μm (c) F25 = 27 μm (c)</p>																							
						<p>Filter element length:</p> <table style="width: 100%; border: none;"> <tr> <td style="width: 25%;">for FRS-10</td> <td style="width: 25%;">for FRS-20</td> <td style="width: 25%;">for FRS-30</td> <td style="width: 25%;">for FRS-40</td> </tr> <tr> <td>A</td> <td>A</td> <td>A</td> <td>A</td> </tr> <tr> <td>B</td> <td>B</td> <td></td> <td>B</td> </tr> <tr> <td></td> <td>C</td> <td></td> <td>C</td> </tr> <tr> <td></td> <td>D</td> <td></td> <td></td> </tr> </table>		for FRS-10	for FRS-20	for FRS-30	for FRS-40	A	A	A	A	B	B		B		C		C		D				
for FRS-10	for FRS-20	for FRS-30	for FRS-40																										
A	A	A	A																										
B	B		B																										
	C		C																										
	D																												

(1) Select the filter element according to the model code reported on the filter nameplate, see section 14.1

(2) Filters with FKM seals are available on request

note: the spare filter element includes the by-pass valve

4 MODEL CODE OF CLOGGING INDICATORS - only for spare

<p>CIA</p> <p>Clogging indicator for return line filter type FRS</p>	-	<p>V</p>	-	<p>**</p> <p>Series number</p>
				<p>Type of indicator:</p> <p>E = Electrical - pressure switch, switching pressure 2 bar V = Visual - pressure gauge, range 0 ÷ 4 bar</p>

5 GENERAL CHARACTERISTICS

Assembly position / location	Vertical position with the bowl downward	
Ambient temperature range	Standard = -20°C ÷ +70°C / PE option = -20°C ÷ +70°C	
Storage temperature range	Standard = -20°C ÷ +80°C / PE option = -20°C ÷ +80°C	
Materials	Filter head	Alluminium alloy
	Filter bowl	Nylon for FRS-10, FRS-20, and FRS-30; steel for FRS-40
Surface protection	Zinc plated (only FRS-40)	

6 HYDRAULICS CHARACTERISTICS

Filter size	10				20					30				40				
Port size code	00	01	11	41	01	02	03	13	43	03	04	14	44	03	04	05	15	45
Ports dimensions	BSPP 1/2"	3/4"			3/4"	1"	1 1/4"			1 1/4"	1 1/2"			1 1/4"	1 1/2"	2"		
	NPT		3/4"					1 1/4"				1 1/2"					2"	
	SAE J1926-1			12					20				24					32
Max operating pressure (bar)	8																	
Max flow (1) (l/min)	44 ÷ 53	45÷55			59 ÷ 125	60 ÷ 192	65÷200			263	275		325 ÷ 512	343 ÷ 530	355÷550			
Direction of filtration	See the arrow on the filter head																	

(1) Max flow rates are performed in following conditions:

- clean filter element
- filtration rating F25 (27 µm (c))
- Δp 0,5 bar
- min ÷ max filter length
- mineral oil with viscosity 30 mm²/s

In case of different conditions the max flow rates have to be recalculated - **see section 10**



7 FILTER ELEMENTS

Material		Inorganic microfibre
Filtration rating as per ISO16889	F10	$\beta_{12\mu\text{m (c)}} \geq 1000$
	F25	$\beta_{27\mu\text{m (c)}} \geq 1000$

8 SEALS AND HYDRAULIC FLUIDS - for other fluids not included in below table, consult our technical office

Seals, recommended fluid temperature	NBR seals (standard) = -25°C ÷ +100°C, with HFC hydraulic fluids = +10°C ÷ +50°C FKM seals (/PE option) = -25°C ÷ +100°C		
Recommended viscosity	15 ÷ 100 mm ² /s - max allowed range 2.8 ÷ 500 mm ² /s		
Hydraulic fluid	Suitable seals type	Classification	Ref. Standard
Mineral oils	NBR, FKM	HL, HLP, HLPD, HVL, HVLDP	DIN 51524
Flame resistant without water	FKM	HFDR, HFDR	ISO 12922
Flame resistant with water	NBR	HFC	

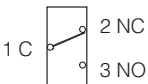
9 CLOGGING INDICATORS

Model code	CIA-E electrical	CIA-V visual
Switching pressure	2 bar	green sector = 0 ÷ 1 bar yellow sector = 1 ÷ 1,5 bar red sector = 1,5 ÷ 4 bar
Switching tolerance at 20°C	± 10% of switching pressure	
Electric connection	Electric plug connection as per DIN 43650 with cable gland type PG7	
Power supply	14 V _{DC} ÷ 30 V _{DC}	125 V _{AC} ÷ 250 V _{AC}
Max current - resistive (inductive)	4 A (3 A) ÷ 3 A (2 A)	5 A (3 A) ÷ 3 A (2 A)
Fluid temperature	-25°C ÷ +100°C	
Protection degree according to DIN 40050	IP65 with mating connector	
Hydraulic connection	G1/8" BSP	G1/8" BSP
Duty factor	100%	
Mass (Kg)	0,16	
Electric scheme / Hydraulic symbol	 <p>The electric scheme shows the switch position in case of clean filter element</p>	

10 FILTERS SIZING

For the filter sizing it is necessary to consider the Total Δp at the maximum flow at which the filter must work.

The Total Δp is given by the sum of filter head Δp plus plus filter bowl Δp plus the filter element Δp :

$$\text{Total } \Delta p = \text{filter head } \Delta p + \text{filter bowl } \Delta p + \text{filter element } \Delta p$$

In the best conditions the total Δp should not exceed 0,5 bar

See below sections to calculate the Δp of filter head and Δp of the filter element

10.1 Q/ Δp DIAGRAMS OF FILTER HEAD + FILTER BOWL

The pressure drop mainly depends on the ports size and fluid density

In the following diagrams are reported the Δp characteristics based on mineral oil with density 0,86 kg/dm³ and viscosity 30 mm²/s

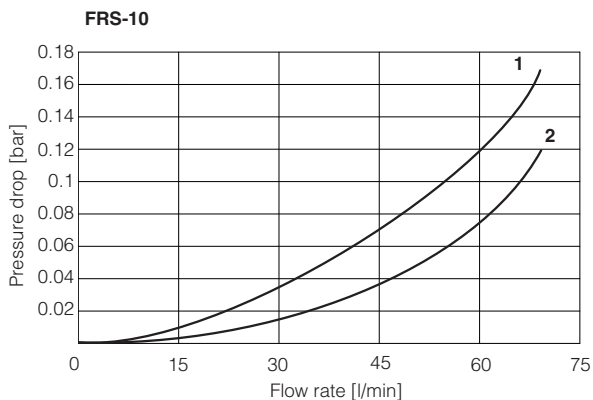

- 1 = FRS-10-*-00-*
- 2 = FRS-10-*-01-*
- FRS-10-*-11-*
- FRS-10-*-41-*

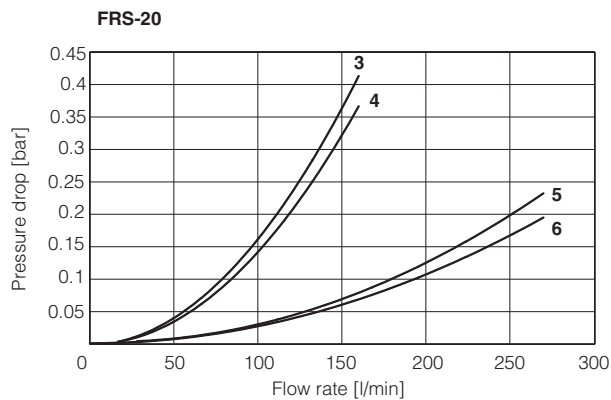

- 3 = FRS-20-*-01-*
- 4 = FRS-20-A-02-*
- FRS-20-B-02-*
- 5 = FRS-20-C-02-*
- FRS-20-D-02-*
- 6 = FRS-20-*-03-*
- FRS-20-*-13-*
- FRS-20-*-43-*

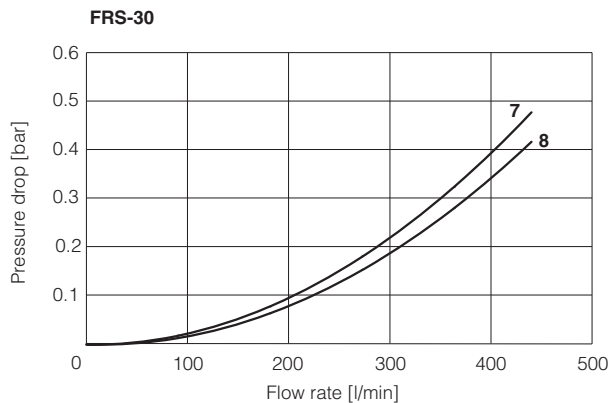

- 7 = FRS-30-*-03-*
- 8 = FRS-30-*-04-*
- FRS-30-*-14-*
- FRS-30-*-44-*

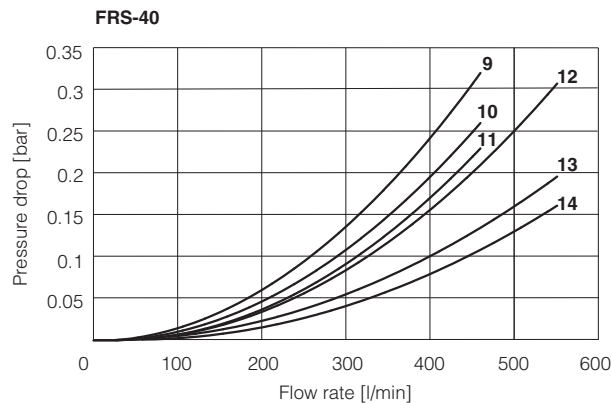

- 9 = FRS-40-A-03-*
- 10 = FRS-40-A-04-*
- 11 = FRS-40-A-05-*
- FRS-40-A-15-*
- FRS-40-A-45-*
- 12 = FRS-40-B-03-*
- FRS-40-C-03-*
- 13 = FRS-40-B-04-*
- FRS-40-C-04-*
- 14 = FRS-40-B-05-*
- FRS-40-B-15-*
- FRS-40-B-45-*
- FRS-40-C-05-*
- FRS-40-C-15-*
- FRS-40-C-45-*

10.2 FILTER ELEMENT Δp

The pressure drop through the filter depends to:

- size of filter element
- filtration rating
- fluid viscosity

The Δp of filter element is given by the formula:

$$\Delta p \text{ of filter element} = Q \times \frac{Gc}{1000} \times \frac{\text{Viscosity}}{30}$$

Q = working flow (l/min)

Gc = Gradient coefficient (mbar/(l/min)). The Gc values are reported in the following table

Viscosity = effective fluid viscosity in the working conditions (mm²/s)

Gradient coefficient Gc of FRS filter elements

Filter element size	10		20				30	40		
Filter element length	A	B	A	B	C	D	A	A	B	C
Filtration rating	Gc Gradient coefficient									
F10	19.8	10.4	10.77	5.86	3.54	2.29	1.62	1.34	0.84	0.61
F25	9.22	7.18	7.14	3.92	2.25	1.88	1.19	0.98	0.52	0.43

Examples:

- 1) calculation of Total Δp for filter type FRS-20-B-F10-02-R at Q = 50 l/min and viscosity 46 mm²/s (filter element PRS-20-B-F10)

Δp of filter head = 0,034 bar

Gr = 5,86 mbar/(l/min)

$$\text{Filter element } \Delta p = 50 \times \frac{5,86}{1000} \times \frac{46}{30} = 0,45 \text{ bar}$$

Total Δp = 0,034 + 0,449 = 0,48 bar

- 2) calculation of Total Δp of filter type FRS-40-C-F25-05-R at Q = 500 l/min and viscosity 46 mm²/s (filter element PRS-40-C-F25)

Δp of filter head = 0,13 bar

Gr = 0,43 mbar/(l/min)

$$\text{Filter element } \Delta p = 500 \times \frac{0,43}{100} \times \frac{46}{30} = 0,33 \text{ bar}$$

Total Δp = 0,13 + 0,33 = 0,46 bar

11 INSTALLATION DIMENSIONS OF FRS FILTERS [mm]

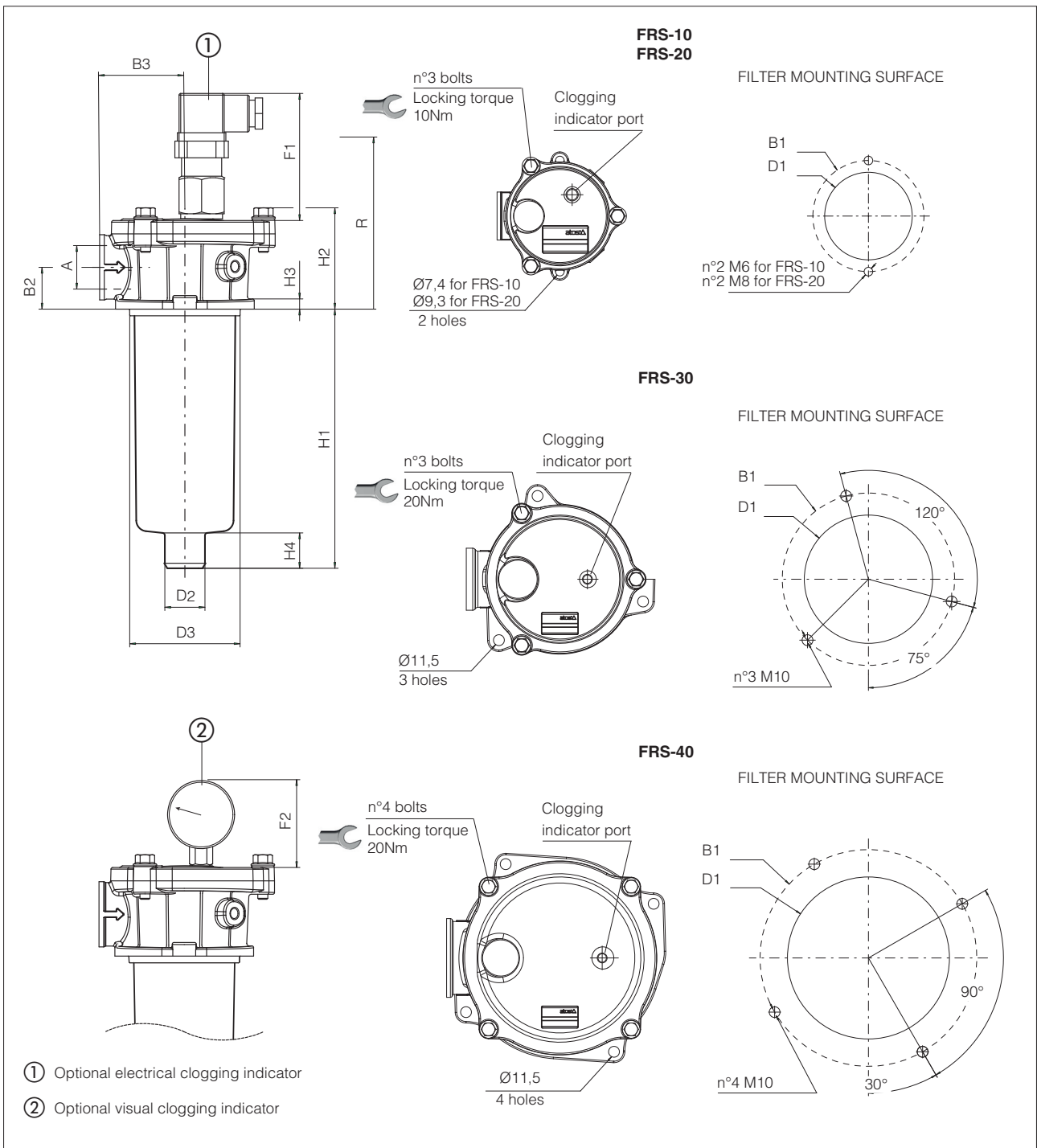

Code	A	B1	B2	B3	D1	D2	D3	H1	H2	H3	H4	F1	F2	R	Mass (Kg)
FRS-10-A	1/2" BSPP 3/4" BSPP 3/4" NPT SAE-12	89	25	51	67,5	24	67	82	60	8	22			150	0,45
FRS-10-B								155						220	0,60
FRS-20-A	3/4" BSPP 1" BSPP 1 1/4" BSPP 1 1/4" NPT SAE-20	115	28,5	67	88,5	40	87	106	73	24		67	50	190	0,80
FRS-20-B								151						230	0,90
FRS-20-C			232					310						1,10	
FRS-20-D			336					420						1,30	
FRS-30-A	1 1/4" BSPP 1 1/2" BSPP 1 1/2" NPT SAE-24	175	35	95	130		129	241	90	11	30			320	2,10
FRS-40-A	1 1/4" BSPP 1 1/2" BSPP 2" BSPP 2" NPT SAE-32	220	42	115	175	63	174	181	105	50				270	3,20
FRS-40-B								240						340	3,60
FRS-40-C								289						380	4,20

12 DIMENSIONS OF CLOGGING INDICATORS

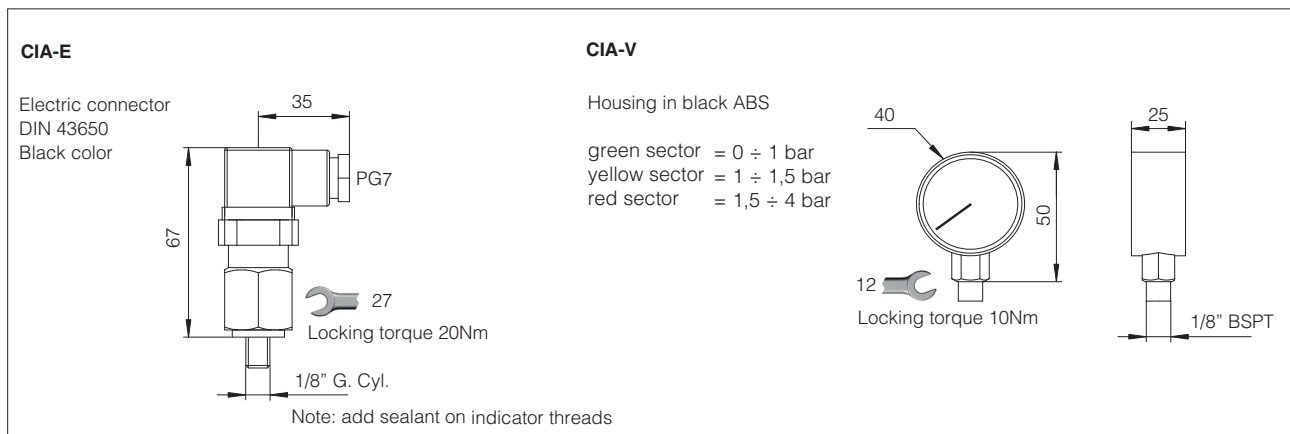

13 INSTALLATION AND COMMISSIONING

The tank flange with the filter mounting surface must be free of scratches.
During the filter installation, pay attention to respect the flow direction, shown by the arrow on the filter head.
The OUT port of the filter can be connected to a pipe which length has to be properly sized so that its end remains under the oil level

The filter head should be properly secured using the threaded fixing holes on the filter head.
Make sure that there is enough space for the replacement of the filter element.

Never run the system without the filter element.

For filters ordered with clogging indicator, code E or V:

- remove the steel plug from the indicator port on the filter head
- install the clogging indicator and lock it at the specified torque

During the cold start up (fluid temperature lower than 30°C), a false clogging indicator signal can be given due to the high fluid viscosity.

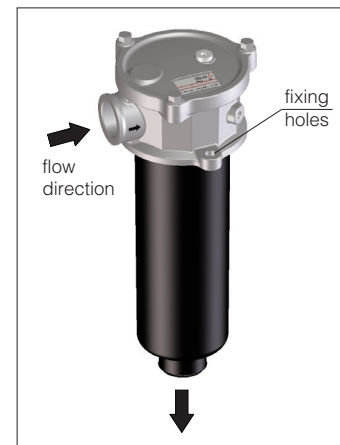

14 MAINTENANCE

The filter element must be replaced as soon as the clogging indicator switches to highlight the filter clogged condition

For filters without clogging indicator, the filter element must be replaced according to the system manufacturer's recommendations.

Select the new filter element according to the model code reported on the filter nameplate, see section 14.1

For the replacement of the filter element, proceed as follow:

- switch-off the system and make sure that there is no residual pressure in the filter line (i.e. pressurized tank); the filter has no pressure bleeding device
- pay attention to the fluid and filter surface temperature. Always use suitable gloves and protection glasses
- remove the cover ① from the filter head ② by releasing the bolts ③
- remove the spring ④ and the bowl ⑦
- remove the dirty filter element ⑥ pulling it upward carefully
- clean the bowl ⑦
- install the bowl ⑦ after having checked the good condition of the seal ⑧
- insert the new filter element over the spigot in the filter bowl; the filter element includes the by-pass valve ⑤
- install the spring ④
- mount the cover and lock the relevant bolts ③ after having checked the good condition of the seal ⑨



WARNING: The dirty filter elements cannot be cleaned and re-used. They are classified as "dangerous waste material", then they must be disposed of by authorized Companies, according to the local laws.

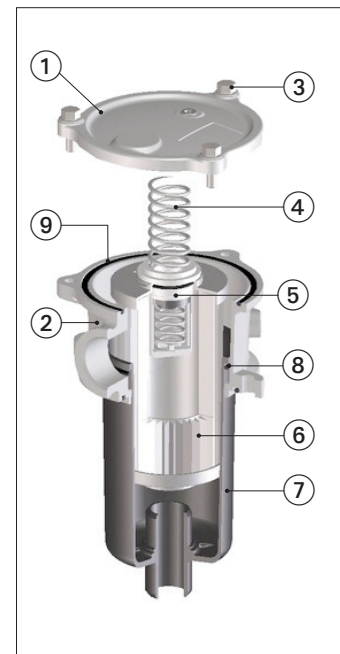

14.1 FILTER IDENTIFICATION NAMEPLATE



- ① Model code of complete filter
- ② Model code of filter element
- ③ Filter matrix code